



**STOELTING®**  
FOODSERVICE EQUIPMENT  
**Model M202-109A, -209A**  
**OWNERS MANUAL**  
Manual No. 513614-1 Rev. 5



**Owner's Manual  
For M202  
Frozen Custard Machine**

This manual provides basic information about the freezer. Instructions and suggestions are given covering its operation and care.

The illustrations and specifications are not binding in detail. We reserve the right to make changes to the freezer without notice, and without incurring any obligation to modify or provide new parts for freezers built prior to date of change.

**DO NOT ATTEMPT** to operate the freezer until instructions and safety precautions in this manual are read completely and are thoroughly understood. If problems develop or questions arise in connection with installation, operation, or servicing of the freezer, contact the company at the following location:

**STOELTING, LLC  
502 Hwy. 67  
Kiel, WI 53042**

**Ph: 800-558-5807**

**Fax: 920-894-7029**

## ***A Few Words About Safety***

### **Safety Information**

**Read and understand the entire manual before operating or maintaining Stoelting equipment.**

This Owner's Manual provides the operator with information for the safe operation and maintenance of Stoelting equipment. As with any machine, there are hazards associated with their operation. For this reason safety is emphasized throughout the manual. To highlight specific safety information, the following safety definitions are provided to assist the reader.

The purpose of safety symbols is to attract your attention to possible dangers. The safety symbols, and their explanations, deserve your careful attention and understanding. The safety warnings do not by themselves eliminate any danger. The instructions or warnings they give are not substitutes for proper accident prevention measures.

If you need to replace a part, use genuine Stoelting parts with the correct part number or an equivalent part. We strongly recommend that you do not use replacement parts of inferior quality.



### **Safety Alert Symbol:**

**This symbol** Indicates danger, warning or caution. Attention is required in order to avoid serious personal injury. The message that follows the symbol contains important information about safety.

### **Signal Word:**

Signal words are distinctive words used throughout this manual that alert the reader to the existence and relative degree of a hazard.



The signal word "WARNING" indicates a potentially hazardous situation, which, if not avoided, may result in death or serious injury and equipment/property damage.



The signal word "CAUTION" indicates a potentially hazardous situation, which, if not avoided, may result in minor or moderate injury and equipment/property damage.

### **CAUTION**

The signal word "CAUTION" not preceded by the safety alert symbol indicates a potentially hazardous situation, which, if not avoided, may result in equipment/property damage.

### **NOTICE**

The signal word "NOTICE" indicates information or procedures that relate directly or indirectly to the safety or personnel or equipment/property.

# TABLE OF CONTENTS

<b>Section</b>	<b>Description</b>	<b>Page</b>
<b>1</b>	<b>Description and Specifications</b>	
1.1	Description.....	1
1.2	Specifications .....	2
<b>2</b>	<b>Installation Instructions</b>	
2.1	Safety Precautions .....	3
2.2	Receiving the Custard Machine.....	3
2.3	Machine Installation .....	3
A.	Running Line Sets.....	3
B.	Running Electrical Connections .....	4
C.	Plumbing Connections .....	4
D.	Receiving and Installing Remote Conensing Units .....	5
E.	Setting in Place and Making Machine Connections.....	5
F.	Running Product and Setting Pressures for the Custard Machine.....	6
<b>3</b>	<b>Initial Set-Up and Operation</b>	
3.1	Operator's Safety Precautions.....	9
3.2	Operating Controls and Indicators.....	9
3.3	Sanitizing .....	10
3.4	Freeze Down and Operation .....	10
3.5	Mix Information .....	11
3.6	Hold Cycle During Operation.....	11
3.7	Production After Hold Cycle.....	11
3.8	Removing Mix.....	11
3.9	Cleaning the Machine.....	12
3.10	Disassembly of Machine Parts .....	12
3.11	Cleaning the Machine Parts .....	12
3.12	Assembly of Machine .....	12
3.13	Routine Cleaning .....	13
3.14	Preventative Maintenance .....	13
3.15	Extended Storage.....	15
<b>4</b>	<b>Troubleshooting</b>	
4.1	Troubleshooting the Machine .....	17
4.2	Troubleshooting the Hopper .....	18
4.3	Troubleshooting the Dipping Cabinet .....	18
<b>5</b>	<b>Replacement Parts</b>	
5.1	Decals and Lubrication .....	19
5.2	Auger Shaft and Faceplate Parts .....	20
5.3	Hopper Parts .....	21



## SECTION 1 DESCRIPTION AND SPECIFICATIONS

### 1.1 DESCRIPTION

The M202 is a frozen custard machine. It is equipped with fully automatic controls to provide a uniform product and features Quick-Freeze technology. This manual is designed to assist qualified service personnel and operators in the installation, operation and maintenance of the M202 frozen custard machine.



Figure 1-1 Model M202A

## 1.2 SPECIFICATIONS

	M202 Air Cooled		M202 Water Cooled	
<b>Dimensions</b>	<b>Machine</b>	<b>with crate</b>	<b>Machine</b>	<b>with crate</b>
	width	42-1/2" (108,0 cm)	27-1/2" (69,9 cm)	42-1/2" (108,0 cm)
	height	67" (170,2 cm)	57-1/2" (146,1 cm)	67" (170,2 cm)
depth	48" (121,9 cm)	32" (81,3 cm)	48" (121,9 cm)	32" (81,3 cm)
<b>Weight</b>	645 lbs (292,5 kg)	945 lbs (428,6 kg)	845 lbs (383,2 kg)	1100 lbs (498,9 kg)
<b>Electrical</b>	<b>1 Phase, 208-240 VAC, 60Hz</b>	<b>3 Phase, 208-240 VAC, 60Hz</b>	<b>1 Phase, 208-240 VAC, 60Hz</b>	<b>3 Phase, 208-240 VAC, 60Hz</b>
	breaker size per barrel	20A	15A	30A
<b>Hopper Condenser</b>	<b>1 Phase, 115 VAC, 60Hz</b> 20A Breaker			
<b>Drive Motor</b>	Two - 2 hp			

	M202*
<b>Refrigerant</b>	R-404A
<b>Charge</b>	24 lbs
<b>AXV</b>	28-32 psig
<b>Head Pressure Regulator (Water Valve)</b>	255 psig
<b>Crankcase Pressure Regulator</b>	25 psig
<b>Lemon Ice AXV</b>	38-42 psig

\* There is a separate refrigeration system for each freezing cylinder. The refrigeration specifications are per freezing cylinder.

	Hopper
<b>F/C</b>	F
<b>Temp</b>	36 °F
<b>Diff</b>	1
<b>Mode</b>	C1
	<b>Hold Cycle</b>
<b>F/C</b>	F
<b>Temp</b>	38 °F
<b>Diff</b>	1
<b>Mode</b>	C1



## SECTION 2 INSTALLATION INSTRUCTIONS

### 2.1 SAFETY PRECAUTIONS

Do not attempt to operate the machine until the safety precautions and operating instructions in this manual are read completely and are thoroughly understood.

Take notice of all warning labels on the machine. The labels have been put there to help maintain a safe working environment. The labels have been designed to withstand washing and cleaning. All labels must remain legible for the life of the machine. Labels should be checked periodically to be sure they can be recognized as warning labels.

If danger, warning or caution labels are needed, indicate the part number, type of label, location of label, and quantity required along with your address and mail to:

**STOELTING, INC.**  
**ATTENTION: Customer Service**  
**502 Hwy. 67**  
**Kiel, Wisconsin 53042**

### 2.2 RECEIVING THE CUSTARD MACHINE

- A. Upon arrival, check the entire machine for any damage that may have occurred during transit. With the method of packaging used, the machine should arrive in excellent condition. The carrier is responsible for all damage in transit, whether visible or concealed. Do not pay the freight bill until the machine has been checked for damage. Have the carrier note any visible damage on the freight bill. If concealed damage or a shortage is found later, advise the carrier within 10 days and request inspection. The customer must place a claim for damages and/or shortages in shipment with the carrier. Stoelting cannot make any claims against the carrier.
- B. Remove the top of the crate using a hammer or pry bar.
- C. Remove the eight lag bolts from the machine using a 1/2" ratchet. Remove the front and rear crate walls.
- D. Remove the four lag bolts located inside the left and right crate walls using 1/2" ratchet. Remove the left and right crate walls.
- E. Remove the plastic wrapping on the machine. Remove the lower front and back panel on the machine.
- F. Remove the four lag bolts located inside machine on the frame with a 9/16" ratchet. Remove the two lag bolts that hold the skid together with a 9/16" socket.

- G. If the machine has the shipping casters or if it is water-cooled, the casters will be in a box located in the hopper pan. A set of casters includes two casters with locks and two casters without locks. Screw the casters into the threaded holes and tighten them using a pair of channel locks. After installing the casters, knock out bottom 4" x 4" of the machine skid.

#### NOTE

*If the machine does not come with casters, install the stainless steel legs. The legs are located in the hopper pan on top of the machine. After installing the legs, use a pallet jack to move machine into place.*

- H. Put front and back panels on the machine.

### 2.3 MACHINE INSTALLATION

The following instructions are intended for a qualified electrician/refrigeration specialist. Do not attempt these procedures unless you are qualified.

#### CAUTION

**Installation MUST be completed by a qualified electrician/refrigeration specialist**

Incorrect installation may cause personal injury, severe damage to the machine and will void factory warranty.

### A. RUNNING LINE SETS

#### NOTE

*If the machine is water-cooled, proceed to "B. Running Electrical Connections".*

*Line sets are not supplied with the machine.*

*The line sets can be installed prior to receiving the custard machine.*

- 1. An air-cooled machine requires a remote condensing unit and line set for each freezing cylinder. The line sets must be 3/8" for the liquid line and 5/8" for the suction line. When running the line sets, each 10' of vertical rise, install a p-trap in the suction line. For every horizontal line set run, pitch the suction line towards the compressor to assist with oil returning back to the compressor.
- 2. After the line set is installed, perform a thorough leak test. Malfunctions of the equipment due to leaks in the line set are not covered by the Stoelting/Ross warranty.

- 3 Insulate the suction line with a minimum of 3/8" wall thickness or the wall thickness required by local code. In humid areas, use thicker insulation. In areas that are exposed to extreme temperatures, insulate the liquid line to prevent excessive sub cooling or heating of the liquid refrigerant. Fasten all lines securely along ceilings, walls and roofs. Avoid creating any type of kink in the lines. The Stoelting/Ross warranty does not cover malfunctions or capacity issues with equipment caused by kinks in the line sets.
- 4 Use good piping practices when installing line sets. Seal the ends of the line sets during installation to prevent exposure to the atmosphere and foreign objects. Blow the lines out with dry nitrogen to remove any debris that might be in the line sets. When running line sets through a wall or roof, mark the lines to eliminate confusion as to which line set is running to which cylinder.  
  
Example: Mark the liquid and suction lines with the respective cylinder number. Facing the front of the machine, cylinders are numbered left to right.
- 5 When brazing the joints, purge dry nitrogen through the lines to minimize oxidation of copper inside of the lines. The Stoelting/Ross warranty does not cover problems with the refrigeration system that are caused by oxidized material in the lines.

## B. RUNNING ELECTRICAL CONNECTIONS

- 1 The machine requires a separate electrical connection for each freezing cylinder. Refer to the nameplate on the machine for proper electrical supply. Each freezing cylinder has its own electrical system and condenser so if one cylinder fails, the other cylinder will still be operational.

### NOTE

*An air-cooled machine needs two circuits for each freezing cylinder, one for the remote condensing unit and one for the freezing cylinder.*

*A water-cooled machine needs one circuit for each freezing cylinder.*

- 2 The electrical boxes are located behind the lower front panel. Labels indicate which cylinder each electrical box powers. No pigtailed are supplied with the machine or condensing unit.
- 3 If the condensing unit is on the roof or ground, a quick disconnect box needs to be installed to provide power.

- 4 Do not turn on the power to the machine or the condensing unit until the refrigeration lines have been connected and the system has been charged with refrigerant. Label the circuit breakers with information regarding which cylinder and condensing unit the breaker is designated for to prevent confusion if power ever needs to be shut off.
- 5 When connecting power to the machine, run the line under the machine and through the bottom of the electrical box. Remove the electrical box cover by loosening the four screws. The screws do not have to be removed. Connect the power to the 4-circuit terminal strip. The 4-circuit terminal strip is labeled L1, L2, L3, and GND. After connections are made, place the cover on the electrical box, but do not tighten the cover (for single-phase machines the cover can be tightened). The electrical box may need to be accessed when checking for proper rotation of the motor.

## C. PLUMBING CONNECTIONS

- 1 On water-cooled machines, the water inlet is a standard garden hose connection and the water outlet is 5/8" OD copper tubing. The connections are located at the back of the machine. Remove the rear panel to access the connections. Run the plumbing under the machine frame. Water-cooled machines use approximately 2 gallons of 75°F water per minute while in use. The machine does not use any water when not in use.
- 2 The machine is equipped with a dipping trough that requires a water inlet line and a drain line. The water inlet has a 1/4" OD brass female connector. Solder a 1/4" line to the water valve inlet using silver solder. Install a shutoff valve in the water inlet line. The drain connection is 1-1/2". Run a drain line from the trough to a drain on the floor. Leave enough slack in the drain line so that the lower front panel can be easily removed for service.
- 3 If the machine is equipped with the hopper faucet option, run the hopper faucet tubing to the dipping trough inlet and install a T. This will supply water needed for the hopper faucet and the water valve for the dipping trough.

## D. RECEIVING AND INSTALLING REMOTE CONDENSING UNITS

### NOTE

*The remote condensing units may be sent prior to delivery of the freezer.*

*The freezer requires one remote condensing unit per cylinder.*

- 1 Upon arrival, check the entire remote condenser units for any damage that may have occurred during transit. With the method of packaging used, the remote condensers should arrive in excellent condition. The carrier is responsible for all damage in transit, whether visible or concealed. Do not pay the freight bill until the remote condenser units have been checked for damage. Have the carrier note any visible damage on the freight bill. If concealed damage or a shortage is found later, advise the carrier within 10 days and request inspection. The customer must place a claim for damages and/or shortages in shipment with the carrier. Stoelting cannot make any claims against the carrier.
- 2 Remove cardboard covering off the condensing units.
- 3 Place the condensing units in their predetermined location, either on the roof or on the ground. A crane or forklift will be needed if the units will be placed on a roof. The condensing units weigh approximately 200 lbs. each.
- 4 Using ratchet with a 1/2" socket, remove the two lag bolts that secure the condensing unit to the pallet.
- 5 Place the condensing units on 4" x 4" treated wood or similar material so that the units are not sitting directly on the ground or the roof. Secure the condensing units to the 4" x 4" using lag bolts. Adhere to all local, state, and federal codes governing this type of installation. Some areas have specific "hurricane-proof" requirements for roof installations. Allow at least 2 feet of clearance on the air intake and discharge sides of the condensers. Do not set the condensers so that one is blowing air directly into the other condensing unit. The ideal set up is to have all the condensing units set in a row (Fig. 2-1).

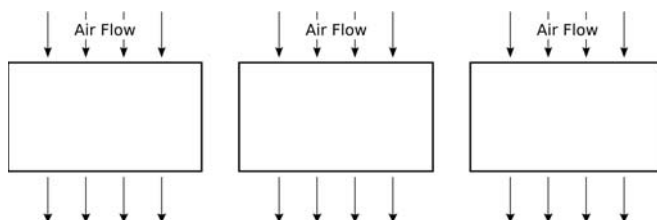

**Figure 2-1 Remote Condenser Installation (Top View)**

Use an Allen wrench to open the shut off valves and release some of the nitrogen charge in the condensing unit. The shut off valves are located on the outside of the condensing unit. If no nitrogen is present then the unit needs to be leak checked prior to connecting the refrigeration lines.

- 7 Braze the suction line and liquid line from the line sets to the condensing unit. When brazing, wrap the shut off valve with a cold wet rag and make sure that the valve is fully open. If valve is not wrapped, damage to the valve may result. When installing the suction line, angle it towards the condensing unit so that oil can flow back towards the compressor.
- 8 Use good piping practices. Keep pipes as clean as possible. Do not let any debris or copper shavings get inside system otherwise the refrigeration valves may not work properly.

## E. SETTING IN PLACE AND MAKING MACHINE CONNECTIONS

- 1 Roll the machine into the desired location. Leave adequate space around the machine for the removal of service panels. Remove the left, right, back and lower front service panels.

### NOTE

*After the refrigeration lines are connected, air-cooled machines cannot be moved.*

- 2 Use a pallet jack or floor jack to lift the front of the machine, remove the two shipping casters with a pair of channel locks, and install the stainless steel legs. Make sure the legs are adjusted all the way in, and screw two of the legs into the frame. Secure them tightly using channel locks. Repeat with the back of the machine.

### NOTE

*If the machine is water-cooled, casters are standard with machine.*

- 3 Accurate leveling is necessary to ensure proper operation. Place a bubble level on top of the machine at each corner to check for level condition. If adjustment is necessary, level the machine by turning the bottom part of each leg or caster in or out.

To finish installing a water-cooled machine, proceed to "G. Running product and setting pressures for the custard machine".

- 4 Connect the refrigeration lines from the line sets to the machine. Access the machine from the left or right service panel. The refrigeration system has a charge of dry nitrogen. Use caution when connecting the lines. Connect the suction line first then connect the liquid line. Run the refrigeration lines under the machine. There is approximately 6" of clearance between machine and the floor. The stainless steel legs are adjustable and can raise the machine up to 7" off the floor if necessary. Wrap the suction solenoid in a cold wet rag when soldering to prevent damage to the solenoid. Also, be aware of the electrical conduit inside custard machine while soldering the refrigeration lines. A liquid line dryer is supplied with the machine and should be the last connection made in the system. Use good piping techniques to keep the system clean. Do not leave the lines open and exposed for a long period.
- 5 After finishing the refrigeration connections, connect power to the machine. Refer to "B. Running Electrical Lines" for the proper procedures. Check the rotation of the beater shaft. When looking at the machine from the front, the shaft needs to turn counterclockwise. If the shaft is turning the wrong direction, shut off power to the cylinder and switch the L1 and L3 wires. Check rotation again to verify the shaft is rotating counterclockwise. Once verified, tighten the screws on the electrical box cover.  
  
If the machine is single phase and the beater shaft rotation is clockwise, then complete one of the following procedures. Check rotation after each procedure.
  - A. Change programming on variable speed drive to reverse motor.
  - B. Change the T1 and T3 output leads going to the motor from the drive.
  - C. Change the leads inside the motor electrical box.
- 6 Check the refrigeration systems for leaks. When pressurizing the system, turn the refrigeration switch to hold position to energize the suction solenoid. Also, make sure that the shut off valves are open on the remote condensing unit. Check the refrigeration system with a minimum of 100 psi. Make sure the system will hold the pressure for a minimum of 2 hours.
- 7 After the leak check, connect a vacuum pump to the system and evacuate it to 500 microns for a minimum of 1 hour. Make sure the suction solenoid and the shut off valves on the condensing unit are opened. Perform a standing vacuum test. If the vacuum deteriorates and continues to rise there is a leak. Find it, repair it, and repeat the evacuation procedure until the machine passes a standing vacuum test. While the refrigeration system is under a vacuum, insulate the suction line. Insulation is needed up to the shut off valve on the condensing unit. Use 3/8" tube insulation or insulation required by local code.
- 8 Use good refrigeration practices to charge the system with the required charge. Air-cooled machines require 20 lbs of refrigerant per cylinder and water-cooled machines require 8 lbs of refrigerant per cylinder. Make sure the suction solenoid is energized and that the shut off valves are open.

**NOTE**

*Air-cooled machines do not ship with refrigerant and require refrigerant to be supplied on site. Water-cooled machines are factory charged. The hoppers for air-cooled and water-cooled machines are factory charged.*

*The charge for air-cooled machines is sufficient for up to a 50 ft. line set. If the line set is longer, add 1 lb. of refrigerant for every 10 ft. of additional line (up to 150 ft. total).*

**F. RUNNING PRODUCT AND SETTING PRESSURES FOR THE CUSTARD MACHINE**

**NOTE**

*Complete the Custard Machine Start-Up and Training Checklist located with the spare parts kit or in the back of this manual and send it to Stoelting.*

- 1 Remove all spare parts from the hopper before running product. Unwrap the parts and check for damage. Refer to the list in the back of this manual to make sure no parts are missing. The cylinders need to be under a load to set the pressures. If custard is not available, RV antifreeze can be used as an alternative. Mix the RV antifreeze in a concentration of 1 part antifreeze to 1 part water. If RV antifreeze is used, the pressures will need to be rechecked when custard mix is available. The RV antifreeze will indicate that the system is functioning correctly.
- 2 Disassemble, clean and sanitize each freezing cylinder. Refer to the Section 3 for proper instructions.

- 3 After assembling and sanitizing the machine, add custard mix to the hopper. Follow the instructions in the Section 3 to start freezing the custard (run one cylinder at a time to set the pressures). Connect gauges to the suction line and the discharge line. When product starts coming out of the faceplate, locate the low pressure gauge on the front of the machine and set the AXV to 30 psi. Remove the white plastic cap from the AXV and turn the valve counterclockwise to decrease the pressure or clockwise to increase the pressure. Turn the valve 1/4 turn at a time and wait at least 1 minute before making another adjustment. Connect a gauge to the suction line at the compressor and make sure the pressure is 25 psi. Adjust the crankcase pressure regulator (CPR) if the pressure is not correct. Remove threaded brass cap on the front of the CPR and adjust the valve with a 5/16" Allen wrench. Connect a gauge to the suction line at the hopper and adjust the hopper AXV to 55 psi.
- 4 Check the faceplate to see if the custard is at the desired texture and temperature. The standard normal serving temperature of frozen custard coming out of the machine is 18°-21°F.
- 5 Set the pressures for the remaining cylinders.

#### **NOTE**

*If the machine is water-cooled, the discharge pressure was already set at the factory. Run custard mix through the machine to double-check and fine-tune the discharge pressure for the particular mix being used.*

*The remote condenser unit has a head pressure control set for a minimum of 255 psi.*

*Chocolate and vanilla mixes run differently. Usually the pressures in the chocolate cylinder will need to be set slightly lower than the pressures in the vanilla cylinder. Custard mixes that use an extract flavoring will also run differently. Try different pressure settings by adjusting the AXV. Adjust the pressure setting between 28-32 psi (the machine will not operate correctly if the AXV is set lower than 28 psi).*

- 6 If the machine is equipped with the lemon ice option, set the lemon ice AXV. The lemon ice option is designated for one cylinder (right cylinder). With the system still running product, turn the lemon ice switch on. The AXV is located behind the cylinder in front of the machine. Set the lemon ice AXV for 38-42 psi.
- 7 When testing is done, take the cylinders apart and clean the custard machine. Refer Section 3 for details.



## SECTION 3 INITIAL SET-UP AND OPERATION

### 3.1 OPERATOR'S SAFETY PRECAUTIONS

SAFE OPERATION IS NO ACCIDENT; observe these rules:

- A. Know the machine. Read and understand the Operating Instructions.
- B. Notice all warning labels on the machine.
- C. Wear proper clothing. Avoid loose fitting garments, and remove watches, rings or jewelry that could cause a serious accident.
- D. Maintain a clean work area. Avoid accidents by cleaning up the area and keeping it clean.
- E. Stay alert at all times. Know which switch, push button or control you are about to use and what effect it is going to have.
- F. Disconnect electrical cord for maintenance. Never attempt to repair or perform maintenance on the machine until the main electrical power has been disconnected.
- G. Do not operate under unsafe operating conditions. Never operate the machine if unusual or excessive noise or vibration occurs.

### 3.2 OPERATING CONTROLS AND INDICATORS

Before operating the machine, it is required that the operator know the function of each operating control. Refer to Figure 3-1 for the location of the operating controls on the machine.

#### **WARNING**

High voltage will shock, burn or cause death. The OFF-ON switch must be placed in the OFF position prior to disassembling for cleaning or servicing. Do not operate machine with cabinet panels removed.

#### A. **Refrigeration Hold/Off/On**

The Refrigeration Hold/Off/On switch is a three-position switch.

**Hold** - When the switch is in the Hold position, the refrigeration system will run until the freezing cylinder and the hopper reach a preset temperature. The refrigeration system cycle on and off to maintain this temperature.

**Off** - When the switch is in the Off position, the refrigeration system will not cool the freezing cylinder.

**On** - When the switch is in the On position and the Beater switch is in the On position, the refrigeration system will run continuously.

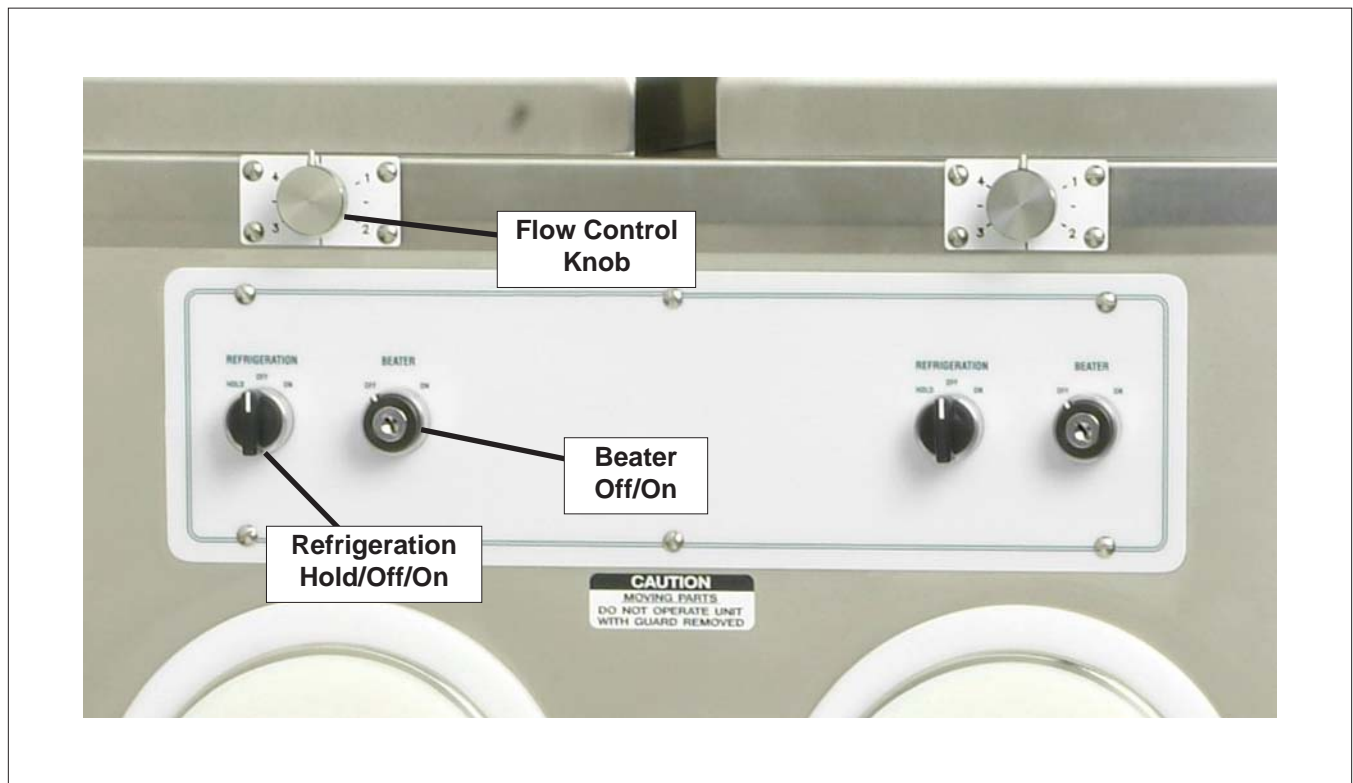

**Figure 3-1 Machine Controls**

**B. Beater Off/On Keyed Switch**

The Beater Off/On switch controls the operation of the beater shaft.

**C. Flow Control Knob**

The Flow Control Knob regulates the amount of mix entering the freezing cylinder.

**3.3 SANITIZING**

Sanitizing must be done after the machine is cleaned and just before the hopper is filled with mix. Sanitizing the night before is not effective. However, you should always clean the machine and parts after each use.

THE UNITED STATES DEPARTMENT OF AGRICULTURE AND THE FOOD AND DRUG ADMINISTRATION REQUIRE THAT ALL CLEANING AND SANITIZING SOLUTIONS USED WITH FOOD PROCESSING EQUIPMENT BE CERTIFIED FOR THIS USE.

When sanitizing the machine, refer to local sanitary regulations for applicable codes and recommended sanitizing products and procedures. The frequency of sanitizing must comply with local health regulations.

Mix sanitizer according to manufacturer's instructions to provide a 100 parts per million strength solution. Mix sanitizer in quantities of no less than 2 gallons (7.5 liters) of 90° to 110°F (32° to 43°C) water. Allow sanitizer to contact the surfaces to be sanitized for 5 minutes. Any sanitizer must be used only in accordance with the manufacturer's instructions.

In general, sanitizing may be conducted as follows:

- A. Prepare Stera-Sheen Green Label Sanitizer or equivalent according to manufacturer's instructions to provide a 100ppm strength solution. Mix the sanitizer in quantities of no less than 2 gallons of 90° to 110°F (32° to 43°C) water. Any sanitizer must be used only in accordance with the manufacturer's instructions.
- B. Place the tapered end of the flow valve into the hopper drain hole with the arm pointing towards the left. Connect the flow control rod to the flow valve and the flow valve arm (Fig. 3-2).
- C. Make sure the flow control valve is shut by turning the control knob counterclockwise to the 12:00 position.
- D. Place a bucket under the slide.
- E. Pour the sanitizer into the hopper.

**NOTE**

*A small amount of sanitizer may drain into the bucket with the flow control shut.*

- F. Place the Beater Off/On switch in the On position.
- G. Turn the flow control knob fully open (clockwise).



**Figure 3-2 Flow Control Assembly**

- H. Clean sides of hopper, flow valve and underside of hopper cover using a sanitized soft bristle brush dipped in the sanitizing solution.
- I. When the sanitizer has drained from the hopper, turn the Beater Off/On switch to the Off position. Allow the freezing cylinder to drain completely.
- J. Shut off the flow control valve by turning the flow control knob counterclockwise to the 12:00 position.

**3.4 FREEZE DOWN AND OPERATION**

This section covers the recommended operating procedures to be followed for the safe operation of the machine.

- A. Sanitize immediately prior to use.

**NOTE**

*Make sure the flow control assembly is in place before adding mix and that the flow control knob is fully closed at the 12:00 position (counterclockwise).*

- B. Fill hopper with approximately 3 gallons (11.4 liters) of pre-chilled (40°F or 4°C) mix.
- C. Place the Refrigeration Hold/Off/On switch in the On position and place the Beater Off/On switch in the On position.
- D. When you hear a chattering sound, open the front gate.
- E. Turn the flow control knob to the 4:00 position until the chattering sound stops.
- F. When the chattering noise stops, turn the flow control knob to the 2:00 position. A small amount of mix and remaining sanitizer will drain from the machine. Discard this mix.

**NOTE**

*Make sure to allow custard mix to flush the sanitizer from the barrel.*

- G. Turn the flow control knob to the 3:00 position (average normal run position).



#### NOTE

*Increase the mix flow by turning the flow control clockwise. Decrease the mix flow by turning the flow control knob counterclockwise.*

- H. Adjust the flow control knob until the product flow fills the faceplate outlet and is at the desired texture (Fig. 3-3). The flow control knob setting will be different for each type of product.

#### NOTE

*Adjustments take up to 1 minute before a noticeable difference is seen in the product.*

#### NOTE

*A high-pitched noise or a rubbing noise from the freezing cylinder is an indication that there is not enough mix entering the barrel. Slowly turn the flow control knob clockwise to increase the flow. It can take up to 1 minute for the adjustment to stop the noise.*



**Figure 3-3 Proper Flow**

### 3.5 MIX INFORMATION

Mix can vary considerably from one manufacturer to another. Differences in the amount of butterfat content and quantity and quality of other ingredients have a direct bearing on the finished frozen product. A change in machine performance that cannot be explained by a technical problem may be related to the mix.

Proper product serving temperature varies from one manufacturer's mix to another. When checking the temperature, stir the thermometer in the frozen product to read the true temperature.

Old mix or mix that has been stored at elevated temperatures will produce poor-quality product with a bad taste and unacceptable appearance. To retard bacteria growth in dairy based mixes, the best storage temperature range is between 36° to 40°F (2.2° to 4.4°C).

### 3.6 HOLD CYCLE DURING OPERATION

After a batch of custard has been made, the remaining product in the hopper can be held for later production.

#### NOTE

*Product in the cylinder MUST be purged to prevent the cylinder from freezing up.*

- Turn the flow control knob fully closed (counterclockwise).
- Place the Refrigeration Hold/Off/On switch in the Hold position.
- When frozen custard stops flowing out of the machine, place the Beater Off/On switch in the Off position and remove the key.

#### NOTE

*The frozen custard should empty from the freezing cylinder in less than 1 minute.*

- Clean the excess frozen custard from the front plate to prevent dripping.
- Replace the key.
- Close the front gate and remove the custard slide.

### 3.7 PRODUCTION AFTER HOLD CYCLE

- Install the custard slide.
- Open the front gate.
- Place the Refrigeration Hold/Off/On switch in the On position and place the Beater Off/On switch in the On position and turn the flow control knob to the 1:00 position.
- When product starts to come out of the freezing cylinder, turn the flow control knob to the 3:00.

#### NOTE

*Increase the mix flow by turning the flow control clockwise. Decrease the mix flow by turning the flow control knob counterclockwise.*

- E. Adjust the flow control knob until the product flow fills the faceplate outlet and is at the desired texture (Fig. 3-3). The flow control knob setting will be different for each type of product.

#### NOTE

*Adjustments take up to 1 minute before a noticeable difference is seen in the product.*

#### NOTE

*A high-pitched noise or a rubbing noise from the freezing cylinder is an indication that there is not enough mix entering the barrel. Slowly turn the flow control knob clockwise to increase the flow. It can take up to 1 minute for the adjustment to stop the noise*

### 3.8 REMOVING MIX

- Place the Refrigeration Hold/Off/On switch in the Off position.

- B. Let the machine rest for 20 minutes to allow the freezing cylinder time to warm before draining the mix from the hopper.
- C. Remove the front gate and install the diverter shield. Turn the flow control knob fully open (clockwise).
- D. Place the Beater Off/On switch in the On position.
- E. Drain all of the mix from the hopper.
- F. Place the Beater Off/On switch in the Off position.
- G. Close the gate.

### 3.9 CLEANING THE MACHINE

#### NOTE

*The frequency of cleaning the machine and machine parts must comply with local health regulations.*

After the mix has been removed from the machine, the machine must be cleaned. To clean the machine, refer to the following steps:

- A. Place a container under the slide of the faceplate. Fill the hopper with at least 2 gallons (7.5 liters) of tap water.
- B. Turn the flow control knob to the 4:00 position.
- C. Open the front gate and place the Beater Off/ On switch in the On position.

#### NOTE

*Make sure the Refrigeration Hold/Off/On switch is in the Off position.*

- D. When the water has drained, place the Beater switch in the OFF position. Allow the freezing cylinder to drain completely.
- E. Prepare detergent water by mixing 2 oz. of Palmolive detergent or equivalent in 2 gallons of 90° to 110°F (32° to 43°C) water. Repeat steps A through D using the detergent solution.

### 3.10 DISASSEMBLY OF MACHINE PARTS

Inspection for worn or broken parts should be made each time the machine is disassembled. All worn or broken parts should be replaced to ensure safety to both the operator and the customer and to maintain good machine performance and a quality product. Frequency of cleaning must comply with local health regulations.

To disassemble the machine, refer to the following steps:

<b>CAUTION</b>
<p><b>Hazardous Moving Parts</b></p> <p>Revolving auger shaft can grab and cause injury. Beater Off/On switch in the Off position and remove the key before disassembling for cleaning or servicing.</p>

- A. Remove the flow control rod and flow control valve from the hopper by pulling straight up.
- B. Remove the slide from the faceplate and remove the faceplate.
- C. Remove the front wear bushing.
- D. Remove the auger assembly from the machine. Pull the auger out of the freezing cylinder slowly. As the auger is being pulled out, carefully remove each of the blades and springs.
- E. Wipe socket lubricant from the drive end (rear) of the auger with a cloth or paper towel.
- F. Remove the rear seal.

### 3.11 CLEANING THE MACHINE PARTS

Place all loose parts in a pan or container and take to the wash sink for cleaning. To clean machine parts refer to the following steps:

- A. Prepare detergent water by mixing 2 oz. of Palmolive detergent or equivalent in 2 gallons of 90° to 110°F (32° to 43°C) water.
- B. Place all parts in detergent solution and clean with provided brushes.
- C. Wash the hopper and freezing cylinder with the detergent water and brushes provided.
- D. Wash the rear seal surfaces on the inside of the freezing cylinder with the detergent water.
- E. Rinse all parts with clean 90° to 110°F (32° to 43°C) water.

#### NOTE

*If the machine is not going to be immediately operated, store the faceplate in a clean and sanitized container in a cooler.*

### 3.12 ASSEMBLY OF THE MACHINE

To assemble the machine parts, refer to the following steps:

#### NOTE

*Petrol Gel sanitary lubricant or equivalent must be used when lubrication of parts is specified.*

#### NOTE

*The United States Department of Agriculture and the Food and Drug Administration require that lubricants used on food processing equipment be certified for this use. Use lubricants only in accordance with the manufacturer's instructions.*

- A. Place the tapered end of the flow valve into the hopper drain hole with the arm pointing towards the left. Connect the flow control rod to the flow valve and the flow valve arm.
- B. Make sure the flow control valve is shut by turning the control knob counterclockwise to the 12:00 position.

- C. Apply a thin film of sanitary lubricant to the rear seal area of the auger shaft.
- D. Install the rear seal.
- E. Lubricate the auger drive (rear) with a small amount of white socket lubricant. A small container of socket lubricant is shipped with the machine (Fig. 3-4).



**Figure 3-4 Auger**

- F. Install two of the springs and auger blades onto the rear of the auger and insert it part way into machine barrel. Rotate auger so another spring and blade can be placed onto the shaft.
- G. Install the remaining auger blades. Push the auger into the machine barrel and rotate it slowly until the auger engages the drive shaft.



**Figure 3-5 Installing Auger Blades**

- H. Lubricate the inside and outside of the front wear bushing and install it onto the auger.
- I. Install the large o-ring onto the front plate and install the faceplate onto the machine.
- J. Install slide, hopper cover and drain tray.
- K. Repeat the assembly instructions on the remaining barrel.

### 3.13 ROUTINE CLEANING

To remove spilled or dried mix from the machine exterior, wash in the direction of the finish with warm soapy water and wipe dry. Do not use highly abrasive materials, as they will mar the finish.

### 3.14 PREVENTATIVE MAINTENANCE

Stoelting recommends following this preventative maintenance schedule to keep the machine clean and operating properly.

#### A. WEEKLY

##### Clean Inside of Machine

Remove all side panels and clean the inside of the machine. Wipe any custard that may have dripped onto the inner panels with a damp soapy towel. Wash the drain tray.

#### B. QUARTERLY

##### Replace Barrel Parts

Follow the Parts Replacement Schedule to keep the machine operating properly.

##### Clean Condenser Coils (and filters if applicable)

The coils on the hopper, dipping cabinet and remote condenser need to be cleaned to ensure proper airflow. Use compressed air to clean the condensers. Blow the air in the opposite direction of the normal airflow. If the condenser has a filter, remove it and vacuum or brush clean. Rinse the filter with clean water and allow it to dry before replacing it on the condenser.

##### Lubricate Flow Control Assembly

With 3-In-One oil, or equivalent, place a few drops of oil between the flow control arm and grommet (Fig. 3-6).



**Figure 3-6 Flow Control Arm Lubrication**

Rotate flow control knob to ensure proper coverage.

#### C. ANNUALLY

##### Replace Barrel Parts

Follow the Parts Replacement Schedule to keep the machine operating properly.

##### Drive Belt Wear and Tension

Inspect the drive belts for wear. Check for wear marks from the belts rubbing on the pulley.

Press firmly on the belts. When tension is properly adjusted, the belt will depress the approximate width of the belt with the pressure of a finger. If an adjustment is necessary, loosen the bolts holding the motor to the frame and push the motor downward. Use a 5' long 2x4 as a lever to get the proper tension, and then tighten the bolts.

#### **Lubricate Motors**

The motor requires a small amount of grease. Use a grease gun with Shell Alvania RL2, Texaco Multifak 2, or equivalent as lubrication. Apply one compression of the grease gun to the grease fitting on the motor. Wipe the motor clean after lubricating.

#### **D. CLEANING AND SANITIZING INFORMATION**

Special consideration is required when it comes to food safety and proper cleaning and sanitizing.

The following information has been compiled by Purdy Products Company, makers of Stera-Sheen Green Label Cleaner/Sanitizer and specifically covers issues for cleaning and sanitizing frozen dessert machines. This information is meant to supplement a comprehensive food safety program.

#### **SOIL MATERIALS ASSOCIATED WITH FROZEN DESSERT MACHINES**

**MILKFAT/BUTTERFAT** – As components of ice-cream/frozen custard mix, these soils will accumulate on the interior surfaces of the machine and its parts. Fats are difficult to remove and help attribute to milkstone buildup.

**MILKSTONE** – Is a white/gray film that forms on equipment and utensils that come in contact with dairy products. These films will accumulate slowly on surfaces because of ineffective cleaning, use of hard water, or both. Milkstone is usually a porous deposit, which will harbor microbial contaminants and eventually defy sanitizing efforts.

Once milkstone has formed, it is very difficult to remove. Without using the correct product and procedure, it is nearly impossible to remove a thick layer of milkstone. (NOTE: general-purpose cleaners DO NOT remove milkstone.) This can lead to high bacteria counts and a food safety dilemma.

**IT IS BEST TO CONTROL MILKSTONE ON A DAILY BASIS BEFORE IT CAN BECOME A SIGNIFICANT FOOD SAFETY PROBLEM.**

In addition to food safety, milkstone can cause premature wear to machine parts which can add to costs for replacement parts or possibly more expensive repairs if worn machine parts are not replaced once they have become excessively worn.

#### **IMPORTANT DIFFERENCES BETWEEN CLEANING AND SANITIZING**

##### **CLEANING vs. SANITIZING**

It is important to distinguish between cleaning and sanitizing. Although these terms may sound synonymous, they are not. BOTH are required for adequate food safety and proper machine maintenance.

##### **CLEANING**

- Is the removal of soil materials from a surface.
- Is a prerequisite for effective sanitizing.

##### **NOTE**

*An UNCLEAN surface will harbor bacteria that can defy sanitizing efforts.*

Bacteria can develop and resist sanitizing efforts within a layer of soil material (milkstone). Thorough cleaning procedures that involve milkstone removal are critical for operators of frozen dessert machines.

##### **SANITIZING**

- Kills bacteria.
- Can be effective on clean surfaces only.

##### **NOTE**

*Using a SANITIZER on an unclean surface will not guarantee a clean and safe frozen dessert machine.*

#### **PROPER DAILY MAINTENANCE: THE ONLY WAY TO ASSURE FOOD SAFETY AND PRODUCT QUALITY**

Proper daily maintenance can involve a wide variety of products and procedures. Overall, the products and procedures fall into three separate categories. (Please note that this is a brief overview intended for informational purposes only.)

1. **CLEANING** – This involves draining mix from the machine barrel and rinsing the machine with water. Next, a cleaner is run through the machine. Then, the machine is disassembled and removable parts are taken to the sink for cleaning.
2. **MILKSTONE REMOVAL** – Since almost all cleaners do not have the ability to remove milkstone, the use of a delimer becomes necessary. Although this procedure may not be needed on a daily basis, it will usually follow the cleaning procedure. It requires letting a delimer solution soak in the machine for an extended period. Individual parts are also soaked in a deliming solution for an extended period (more about delimers in Additional Information).
3. **SANITIZING** – After the machine has been cleaned and contains no milkstone, the machine is reassembled. Then a FDA-approved sanitizing solution is run through the machine to kill bacteria. The machine is then ready for food preparation.

As a recommended cleaner and sanitizer for your frozen dessert machine, STERA-SHEEN has proven to be one of the best daily maintenance products for:

- **CLEANING** – Thorough removal of all solids including butterfat and milk fat.
- **MILKSTONE REMOVAL** – Complete removal of milkstone.
- **SANITIZING** – FDA-approved no rinse sanitizer for food contact surfaces.

### ADDITIONAL INFORMATION

#### THE USE OF DELIMERS

A delimer is a strong acid that has the ability to dissolve milkstone. This type of chemical may become necessary once high levels of milkstone have developed. While these products are very effective for removing HIGH levels of milkstone, they are not ideal for two reasons:

1. **PRODUCT SAFETY** – Strong acids are dangerous chemicals and handling them requires safety
2. **MACHINE DAMAGE** – Strong acids will attack metal and rubber causing premature wear of parts. The use of a delimer needs to be closely monitored to avoid damage to machine surfaces and parts.

With proper daily use of STERA-SHEEN or its equivalent, there is no need for the use of a DELIMER.

#### DO NOT USE BLEACH

- **BLEACH HAS ABSOLUTELY NO CLEANING PROPERTIES.**
- **BLEACH IS CORROSIVE.** It can and will damage components of the machine causing premature wear and metal corrosion.

#### GENERAL PURPOSE CLEANERS

General purpose cleaners do not have the ability to remove milkstone. Milkstone will become a problem if not remedied with additional products and procedures.

#### THE USE OF CHLORINE TEST STRIPS

“Test strips” are used to determine concentrations of active chlorine in sanitizing solutions. To use the strips, tear off a small portion and submerge it into the sanitizing solution. Then, compare the color change to the color key on the side of the test strip dispenser to determine the approximate chlorine concentration.

The ideal concentration of chlorine needs to be 100 ppm (as stated by the FDA).

#### NOTE

*Follow the directions on the container for proper concentration.*

There are two main factors that contribute to falling chlorine concentrations in a sanitizing solution.

1. **PRODUCT USE** – As the chlorine in the solution is being used, chlorine concentrations fall.

2. **TIME** – As time passes, small amounts of chlorine “evaporate” from the solution. (That is why you can smell it.)

Sanitizing solutions should not be allowed to fall below 100 ppm chlorine. New solutions should be mixed once old solutions become ineffective.

### 3.15 EXTENDED MACHINE STORAGE

Refer to the following steps for storage of the machine over any long shutdown period:

- A. Turn the Main Machine Power OFF-ON switch to the OFF position.
- B. Disconnect (unplug) from the electrical supply source.
- C. Clean thoroughly with a warm water detergent all parts that are exposed to the mix. Rinse in clean water and dry parts. Do not sanitize.

#### NOTE

*Do not let the cleaning solution stand in the hopper or in the machine barrel during the shutdown period.*

- D. Remove, disassemble and clean the faceplate, flow control assembly and auger parts. Place the auger blades and the front auger wear bushing in a plastic bag with a moist paper towel to prevent them from becoming brittle.
- E. On water cooled machines, shut off and disconnect water supply at rear of freezer; run the compressor for 2-3 minutes to open water valve, and blow out all water first through the inlet line then through the outlet line using air or carbon dioxide.



## SECTION 4 TROUBLESHOOTING

### 4.1 TROUBLESHOOTING THE FREEZER

PROBLEM	POSSIBLE CAUSE	REMEDY
<b>Custard is running too cold or auger blades chatter during running:</b>	<ol style="list-style-type: none"> <li>1. Flow is not high enough.</li> <li>2. Hopper is low or out of mix.</li> <li>3. Flow valve is plugged.</li> <li>4. The refrigeration system is set too cold for the mix.</li> </ol>	<ol style="list-style-type: none"> <li>1. Increase the flow. Machine needs to run for at least a minute before you see a change in the product.</li> <li>2. Add Mix</li> <li>3. Check flow valve.</li> <li>4. Call a service technician for proper setting adjustment.</li> </ol>
<b>Custard is running too soft:</b>	<ol style="list-style-type: none"> <li>1. Flow is too high.</li> <li>2. The refrigeration system for that barrel set too warm for the mix.</li> <li>3. Condenser on remote unit is blocked.</li> <li>4. Water cooled machine has water shut off.</li> <li>5. Refrigeration system not functioning correctly.</li> </ol>	<ol style="list-style-type: none"> <li>1. Decrease the flow. Machine needs to run for at least a minute before you see a change in the product.</li> <li>2. Call a service technician for proper setting adjustment.</li> <li>3. Check for blockage and clean if necessary.</li> <li>4. Check that water is connected and turned on.</li> <li>5. Call a service technician to check the refrigeration system.</li> </ol>
<b>Beater motor freezes up in the run mode:</b>	<ol style="list-style-type: none"> <li>1. Hopper is low or out of mix.</li> <li>2. Flow valve is plugged.</li> <li>3. Flow valve is set too low.</li> <li>4. Front gate is closed and barrel is full of product.</li> <li>5. Belt is loose and slipping</li> </ol>	<ol style="list-style-type: none"> <li>1. Add Mix</li> <li>2. Check flow valve.</li> <li>3. Increase the flow setting.</li> <li>4. Open front gate and purge barrel.</li> <li>5. Check the belt and tighten if necessary.</li> </ol>
<b>Hold cycle not running:</b>	<ol style="list-style-type: none"> <li>1. Refrigeration switch is not on the hold cycle.</li> <li>2. Temperature control is set too warm.</li> <li>3. Refrigeration circuit breaker has tripped.</li> <li>4. Machine is not plugged in.</li> <li>5. Air flow to remote condenser is blocked.</li> <li>6. Water cooled machine has water shut off.</li> <li>7. Refrigeration system not functioning correctly.</li> </ol>	<ol style="list-style-type: none"> <li>1. Make sure the switch is on the hold cycle.</li> <li>2. Refer to the control refrigeration settings.</li> <li>3. Reset circuit breaker</li> <li>4. Make sure the electrical plug is connected to the outlet.</li> <li>5. Check for blockage and clean if necessary.</li> <li>6. Check that water is connected and turned on.</li> <li>7. Call a service technician to check the refrigeration system.</li> </ol>
<b>Beater motor does not function:</b>	<ol style="list-style-type: none"> <li>1. The beater motor reset needs to be reset.</li> <li>2. Machine is not plugged in.</li> <li>3. Refrigeration circuit breaker has tripped.</li> </ol>	<ol style="list-style-type: none"> <li>1. Push the reset button located on the service side of the machine.</li> <li>2. Make sure the electrical plug is connected to the outlet.</li> <li>3. Reset circuit breaker</li> </ol>

#### 4.2 TROUBLESHOOTING THE HOPPER

PROBLEM	POSSIBLE CAUSE	REMEDY
<b>Custard stored in hopper is too cold</b>	<ol style="list-style-type: none"> <li>1. Temperature control is set too cold.</li> <li>2. Refrigeration system not functioning correctly.</li> </ol>	<ol style="list-style-type: none"> <li>1. Refer to the control refrigeration settings.</li> <li>2. Call a service technician to check the refrigeration system.</li> </ol>
<b>Custard stored in hopper is too warm</b>	<ol style="list-style-type: none"> <li>1. Temperature control is set too warm.</li> <li>2. There is no display on the temperature control.</li> <li>3. Hopper condenser coil is dirty.</li> <li>4. Refrigeration system not functioning correctly.</li> </ol>	<ol style="list-style-type: none"> <li>1. Refer to the control refrigeration settings.</li> <li>2. Call a service technician to check the refrigeration system.</li> <li>3. Clean condenser coil with a soft brush or condenser cleaner.</li> <li>4. Call a service technician to check the refrigeration system.</li> </ol>

#### 4.3 TROUBLESHOOTING THE DIPPING CABINET

PROBLEM	POSSIBLE CAUSE	REMEDY
<b>Custard stored in cabinet too cold</b>	<ol style="list-style-type: none"> <li>1. Custard in cabinet is old.</li> <li>2. The temperature control settings are incorrect.</li> <li>3. Refrigeration system not functioning correctly.</li> </ol>	<ol style="list-style-type: none"> <li>1. Custard stored in the cabinet for more than 2 hours tends to become cold and firm.</li> <li>2. Refer to the control refrigeration settings.</li> <li>3. Call a service technician to check the refrigeration system.</li> </ol>
<b>Custard stored in cabinet too warm:</b>	<ol style="list-style-type: none"> <li>1. The temperature control settings are incorrect.</li> <li>2. Cabinet is not plugged in.</li> <li>3. Cabinet condenser coil is dirty.</li> </ol>	<ol style="list-style-type: none"> <li>1. Refer to the control refrigeration settings.</li> <li>2. Make sure the electrical plug is connected to the outlet.</li> <li>3. Clean condenser coil with a soft brush or condenser cleaner.</li> </ol>
<b>Dipping Cabinet not cooling at all:</b>	<ol style="list-style-type: none"> <li>1. Cabinet is not plugged in.</li> <li>2. Cabinet condenser coil is dirty.</li> <li>3. Refrigeration system not functioning correctly.</li> </ol>	<ol style="list-style-type: none"> <li>1. Make sure the electrical plug is connected to the outlet.</li> <li>2. Clean condenser coil with a soft brush or condenser cleaner.</li> <li>3. Call a service technician to check the refrigeration system.</li> </ol>



## SECTION 5 REPLACEMENT PARTS

### 5.1 DECALS, LUBRICATION AND ACCESSORIES

Part	Description	Quantity
BR-0020	Brush - Tubing (1/2")	1
BR-0030	Brush - Head (Barrel)	1
BR-0035	Brush - Handle (Barrel)	1
C74	O-Ring Pick	1
C-1000-24J	Decal - Flow Control Settings	2
C-1000-24N	Decal - Warning Electrical Shock	0
C-1000-25F	Decal - Caution Use Water Under 100°F	2
C-1000-25I	Decal - Left Barrel	1
C-1000-25K	Decal - Right Barrel	1
C-1000-25N	Decal - Left Hopper	1
C-1000-25O	Decal - Right Hopper	1
C-1000-25T	Decal - Warning Moving Parts	1
C-1000-26C	Decal - Made in USA	1
C-2000-57	Wrench - Beater Shaft	1
C-2000-61	Leg (Ser. #0-#28118)	-
C-4000-14	Guard Splash	1
C-5000-20	Divider	-
CA-0010	Caster - Locking (Ser. #0 - #28118)	-
CA-0020	Caster - Non-Locking (Ser. #0 - #28118)	-
244138	Caster - Non-Locking (4") (Each) (Ser. #28119 Plus)	2
244139	Caster - Locking (4") (Each) (Ser. #28119 Plus)	2
324509	Decal - Cleaning Instructions	-
324566	Decal - Wired According To	-
324878	Decal - #149014 Wearguard	-
324879	Decal - #149003 Wearguard	-
324881	Decal - #149017 Wearguard	-
324882	Decal - #C-2000-40 Wearguard	-
324883	Decal - #149018 Wearguard	-
324900	Decal - Safety Warning Alert	-
490760	Leg (Ser. #28119 Plus)	-
508048	Lubricant - Spline (2 oz Squeeze Tube)	1
508135	Petrol Gel - 4 oz Tube	1
719102-KY	Keys	2
2183894	Alignment Kit	-

## 5.2 AUGER SHAFT AND FACEPLATE PARTS

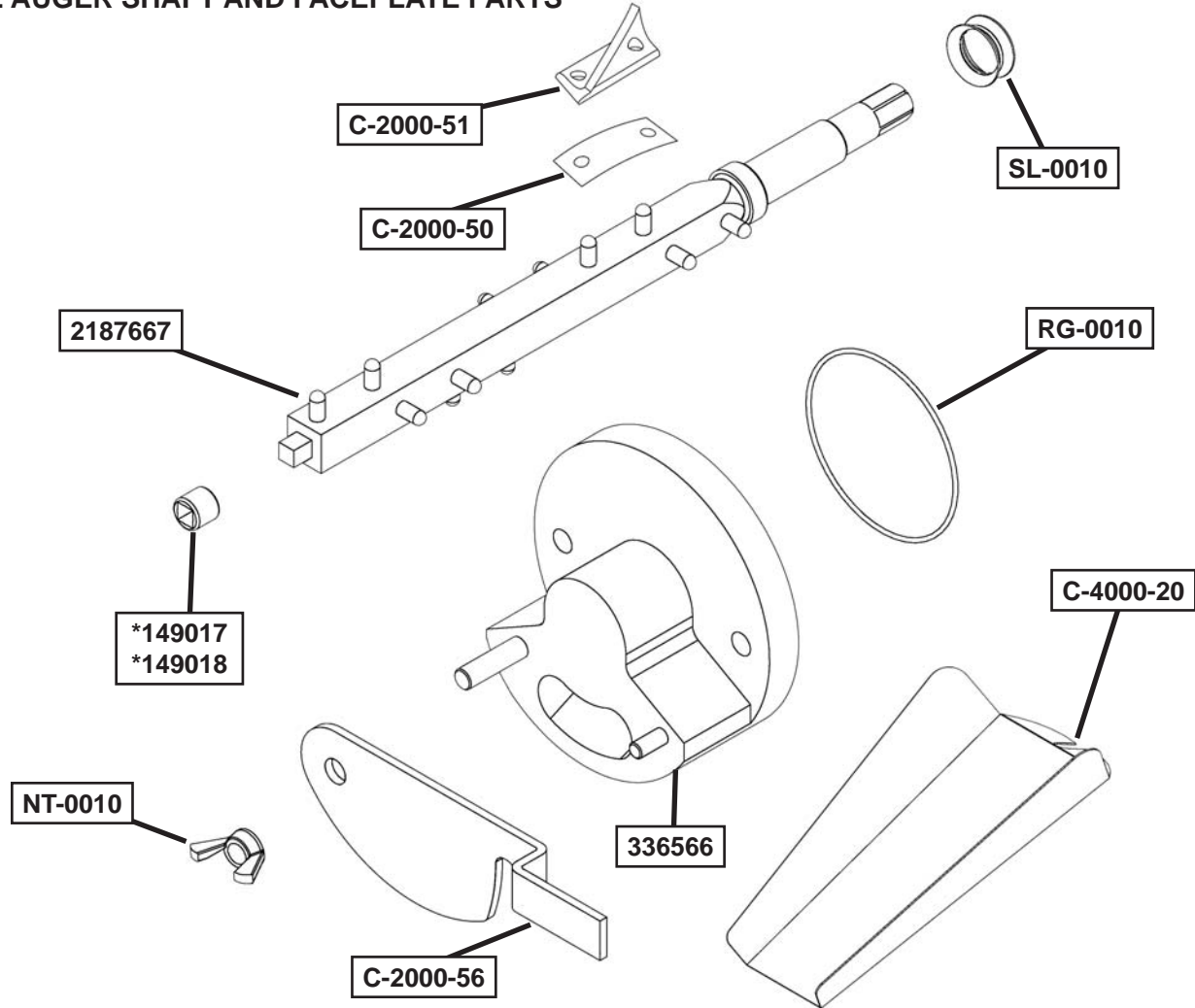

Part	Description	Quantity
* C-2000-40	Wearguard - Beater Shaft (Ser. #0-#29019)	2
C-2000-50	Spring	20
C-2000-51	Blade (10 per Barrel)	20
C-2000-56	Gate - Front	2
C-4000-19	Slide - Long (Chute)	2
C-4000-20	Slide - Short (Chute)	2
NT-0010	Wing Nut - Stainless Steel	4
RG-0010	O-Ring - Face Plate	2
SL-0010	Seal - Beater Shaft (Ser. #27292 Plus)	2
* 149017	Wearguard - Front Beater Shaft (Small)	-
* 149018	Wearguard - Front Beater Shaft (Large)	-
336566	Plate - Front (Ser. #29020 Plus)	2
336595	Plate - Front w/Stainless Steel Insert (Ser. #0-#29019)	2
336599	Plate - Front (For Rounded Shaft Front / No Wear Guard) (Ser. #0-#29019)	-
624678-5	O-Ring - Rear Seal - Black (5 Pack) (Ser. #25245 - #27291)	-
667868	Seal - Rear Beater (Orange) (Ser. #25245 - #27291)	-
674194	Beater Shaft (Ser. #0-#25244)	-
1151859	Adapter - Rear Seal (Code 1) (May require C-5000-66, C5000-67 and SL-0010) (Ser. #25245 - #27291)	-
2187667	Beater Shaft (Ser. #29020 Plus)	2
2187701	Beater Shaft (Ser. #25245 - #27291 - May Require C-5000-66, C-5000-67 & SL-0010) (Ser. #27292 - #29019 - Requires Shaft Only)	2

\* Check for a "S" or "L" marking on the side of the bushing prior to ordering.

## 5.1 HOPPER PARTS

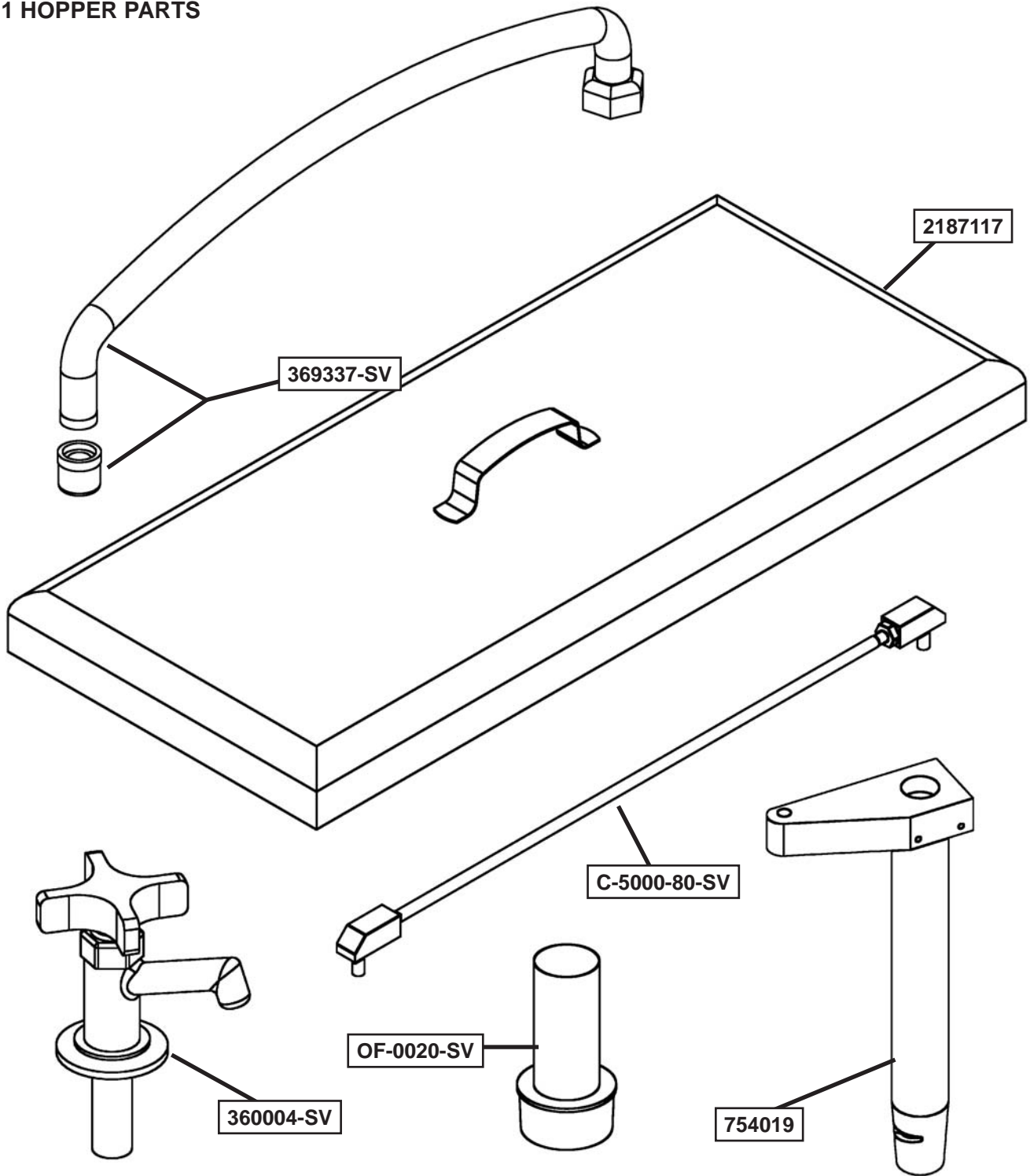

Part	Description	Quantity
C-5000-80-SV	Flow Control Rod	2
FA-0010	Faucet - Swing-Out	-
HO-0010	Faucet - Pull-Out	-
OF-0020-SV	Overflow	1
360004-SV	Faucet Assembly - Trough	1
369336	Aerator - Swing Faucet	1
369337	Faucet Arm - Swing Style	1
369337-SV	Faucet Arm Kit (Arm & Aerator)	1
754019	Flow Control Valve Assembly (Hopper) (Ser. #25245 Plus)	2
2187117	Hopper Cover	2





## ROSS & TELME WARRANTY

### 1. Scope:

Stoelting, LLC warrants to the first user (the "Buyer") that the freezing cylinders, hoppers, compressors, drive motors, speed reducers, beaters and agitator of Stoelting Ross and Telme product line will be free from defects in materials and workmanship under normal use and proper maintenance appearing within two (2) years, and that all other components of such equipment manufactured by Stoelting will be free from defects in material and workmanship under normal use and proper maintenance appearing within twelve (12) months after the date that such equipment is originally installed.

### 2. Disclaimer of Other Warranties:

**THIS WARRANTY IS EXCLUSIVE; AND STOELTING HEREBY DISCLAIMS ANY IMPLIED WARRANTY OF MERCHANTABILITY OR FITNESS FOR PARTICULAR PURPOSE.**

### 3. Remedies:

Stoelting's sole obligations, and Buyer's sole remedies, for any breach of this warranty shall be the repair or (at Stoelting's option) replacement of the affected component at Stoelting's plant in Kiel, Wisconsin, or (again, at Stoelting's option) refund of the purchase price of the affected equipment, and, during the first twelve (12) months of the warranty period, deinstallation/reinstallation of the affected component from/into the equipment. Those obligations/remedies are subject to the conditions that Buyer (a) signs and returns to Stoelting, upon installation, the Checklist/Warranty Registration Card for the affected equipment, (b) gives Stoelting prompt written notice of any claimed breach of warranty within the applicable warranty period, and (c) delivers the affected equipment to Stoelting or its designated service location, in its original packaging/crating, also within that period. Buyer shall bear the cost and risk of shipping to and from Stoelting's plant or designated service location.

### 4. Exclusions and Limitations:

This warranty does not extend to parts, sometimes called "wear parts", which are generally expected to deteriorate and to require replacement as equipment is used, including as examples but not intended to be limited to o-rings, auger seals, auger support bushings and drive belts. All such parts are sold

**AS IS.**

Further, Stoelting shall not be responsible to provide any remedy under this warranty with respect to any component that fails by reason of negligence, abnormal use, misuse or abuse, use with parts or equipment not manufactured or supplied by Stoelting, or damage in transit.

**THE REMEDIES SET FORTH IN THIS WARRANTY SHALL BE THE SOLE LIABILITY STOELTING AND THE EXCLUSIVE REMEDY OF BUYER WITH RESPECT TO EQUIPMENT SUPPLIED BY STOELTING; AND IN NO EVENT SHALL STOELTING BE LIABLE FOR ANY INCIDENTAL OR CONSEQUENTIAL DAMAGES, WHETHER FOR BREACH OF WARRANTY OR OTHER CONTRACT BREACH, NEGLIGENCE OR OTHER TORT, OR ON ANY STRICT LIABILITY THEORY.**